

PRESENTER INSTRUCTIONS

CUBES & LIQUIDS

APPLYING SIX CAPABILITIES ESSENTIAL TO SUCCESS
IN SECONDARY SCHOOL SCIENCE, TECHNOLOGY & MATHEMATICS

OBSERVE
DESCRIBE
PREDICT
TEST

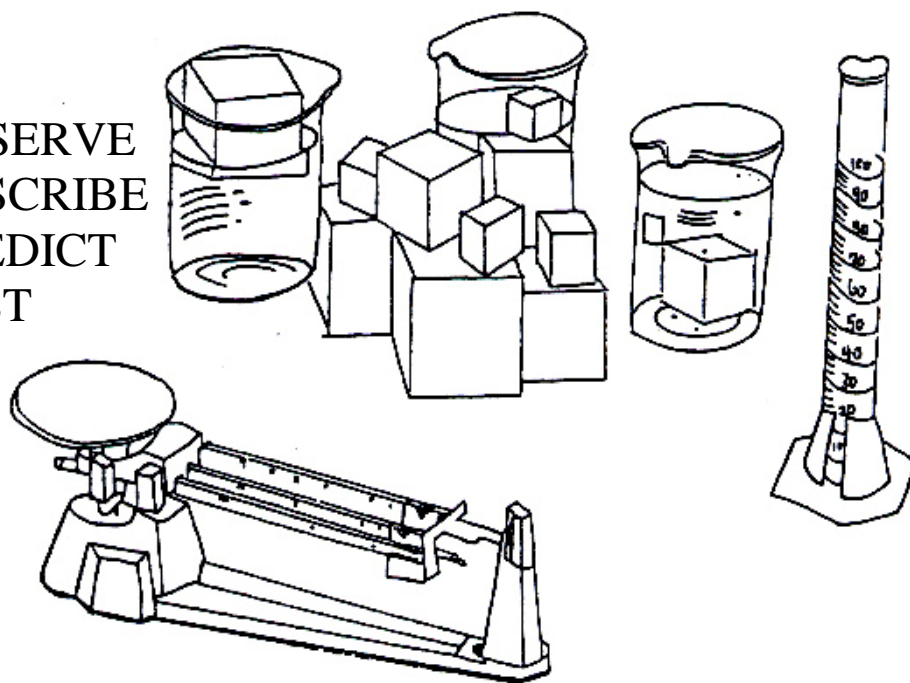

Presenter Instructions: Cubes and Liquids

MATERIALS

- Scale (Balance scale is preferred)
- Two clear beakers (2000 ml size)
 1. Beaker with 1000 ml de-ionized water
 2. Beaker with 1000 ml rubbing alcohol
- Four cubes
 1. “Large cube” 6cm, ~195 grams
 2. “Small cube” 4cm, same weight as large cube
 3. “Mystery cube”, same size as large cube, different weight
 4. “Tiny cube” 1 cm
- Roll of paper towels
- Tongs

SPECIAL INSTRUCTIONS TO PRESENTER:

To ensure that the water and alcohol are indistinguishable:

- Bring beaker of water to room temperature and stir out bubbles.
- Keep students from smelling the alcohol.
- Replace alcohol to keep fresh and clear as needed.

Introduce Task by Telling a Story... in this case the Story of Socrates

Say: *Today I'm going to ask you to take a journey with me...a journey through time and space. We will visit ancient Athens about 2,500 years ago and meet a man named Socrates. Are you familiar with Socrates?*

Action: Elicit what students know.

Say: *Yes, it's well known that Socrates was a great philosopher. But he was not always a philosopher. He was a decorated war hero who defended Athens in the wars with the Persians. By trade he was a craftsman, a potter.*

One day a person came into his studio. This person had just been to the Oracle of the god Apollo in the city of Delphi. The oracle was a priestess who went into a trance and spoke for the god. There someone had posed a question to the oracle: "Who is the wisest person in the world?"

"Why, Socrates who lives in Athens, of course," replied the oracle.

This news came as a great surprise to Socrates, because he had never thought of himself as wise at all, let alone the wisest person in the world. But Socrates was a devout man and he felt that he needed to take a pronouncement by the god seriously. So he put aside his profession for a year and traveled around the Greek-speaking world visiting all the people who were reputed to be wise. He visited doctors, lawyers, politicians, teachers, generals, philosophers, priests, everybody he could find who had a reputation for being wise. And at the end of the year he came to a surprising conclusion. He decided that maybe the Oracle was right after all. Socrates found that these famous "wise" people didn't really know as much as they thought they did. He also noticed that there was one way in which he was wiser than any of them; he knew what he did not know.

This is relevant for science because good scientists not only know what they know but they have a good sense of what they don't know. This is also important for what we are going to do today. We're going to do some experiments and I will be asking you some questions and sometimes the best answer that you will be able to give is that you don't have enough information to answer the question. So it will be important to know how to keep what you know and what you don't know separate.

Describe what students will need to do

Say: *I'm going to give you some problems that require you to think carefully. **You need to figure out a way to predict whether these cubes will float or sink in a liquid without actually immersing them.***

There are no tricks involved. Everything is exactly what you see and what I tell you about it.

Assure that the students grasp what they need to do

Action: Have students attempt to state the task and the goal until agreement is reached.

Present Special Instructions to students concerning “Observation”

Say: *Note that in the pages in front of you there are sections titled “**Observation**”.*

*In these sections be careful to write down only what you have observed. What did the experimenter do? What did you see happen as a result? Just describe what you have observed. Do not try to interpret or explain anything. **Describe what you saw so that someone who is not here would be able to reconstruct what we did and what happened.***

Present Special Instructions Regarding Grading Criteria and assure that students have grasped the criteria

Say:

I want you to know that you will receive a grade for your performance in this activity. The grade, however, will have nothing to do with whether you get the correct answers.

You will be graded on three criteria:

Complete each section.

Write complete sentences for all sections where you are asked to.

Write neatly so that I can read your responses easily.

*So try your best and don't worry that the answers that you give might be wrong. **The important thing is for me to find out what you know and what you don't know so that I will have an idea about how best to teach this subject to you.***

I want to ask you to restate the grading criteria so that I know that you understand them.

Action: Have students attempt to state the grading scheme until agreement is reached.

Insure Independent Work

Say:

Please make your own reports. I want to know what each of you individually thinks. You will be writing your responses and questions—we will not be discussing them today.

Introduce Experiment 1 - Demonstrate with the large cube and beaker of alcohol, request predictions and reasoning.

Action: Hold the large cube over the beaker of alcohol.

Say:

*I pick up this cube and hold it over this beaker. If I immerse it into the liquid, will it float or sink? We are not going to discuss it now. Instead you're going to record your responses and any questions that you may have on your pages. Look at **Prediction 1** in the pages I gave you.*

*For **Prediction 1**, I want you to predict if this cube will float or sink in this liquid. Note that there is a third possibility. You may decide that there is not enough information to tell if the cube will float or sink. Check the appropriate box under **Prediction 1** to indicate whether you believe it will float or sink or whether there is not enough information.*

Then, in the space provided immediately under that, use full sentences to give the reasons why you chose this answer.

Students see:

Prediction 1: Check one. The cube will:

- float
- sink
- not enough information

Reasons for your answer (use full sentences):

Perform Experiment 1

Action: Using tongs, carefully place the large cube in the alcohol. Once it has settled and it is clear that the cube has sunk, remove the cube from the liquid and dry it off.

Say: *Describe what I did and what happened in our experiment where it says **Observation 1**. Using full sentences, write down only what you observed. Remember that your description should allow someone who is not in the room to reconstruct the experiment.*

Students see: **Observation 1** (use full sentences):
Record the details of our experiment.
Describe fully what the experimenter did and what happened as a result.

Introduce Experiment 2 - Demonstrate with the small cube and beaker of alcohol, request predictions and reasoning.

Action: Hold the small cube over the beaker of alcohol.

Say: *Here is a second cube, smaller than the first.*
Now I will tell you something about these two cubes. They both weigh the same. Let's check them and see.

Action: Weigh the two cubes to demonstrate. Then pick up the small cube again and hold it over the beaker of alcohol.

Say: *I pick up this cube and hold it over this beaker. If I place it into the liquid, will it float or sink?*
*Now I want you to predict if this cube will float or sink in this liquid. Check in the appropriate box under **Prediction 2** to indicate whether it will float or sink or whether there is not enough information.*

Students see:

Prediction 2: Check one. The cube will:

- float
- sink
- not enough information

Reasons for your answer (use full sentences):

Perform Experiment 2

Action: Using tongs, carefully place the small cube in the alcohol. Once it has settled and it is clear that the cube has sunk, remove the cube from the liquid and dry it off.

Say:

*Describe what I did and what happened in our experiment where it says **Observation 2**. Using full sentences, write down only what you observed.*

Students see:

Observation 2 (use full sentences):

Record the details of our experiment.

Describe fully what the experimenter did and what happened as a result.

Introduce Experiment 3 - Demonstrate with the large cube and beaker of water, request predictions and reasoning.

Action: Hold the large cube over the beaker of water.

Say:

*I pick up this object and hold it over this beaker. If I place it into the liquid, will it float or sink? Check in the appropriate box under **Prediction 3** to indicate whether it will float or sink or whether there is not enough information.*

Students see:

Prediction 3: Check one. The cube will:

- float
- sink
- not enough information

Reasons for your answer (use full sentences):

Perform Experiment 3

Action: Using tongs, carefully place the large cube in the water. Once it has settled and it is clear that the cube floats, remove the cube from the liquid and dry it off.

Say: *Describe what I did and what happened in our experiment where it says*
Observation 3.

Students see:

Observation 3 (use full sentences):

Record the details of our experiment.

Describe fully what the experimenter did and what happened as a result.

Introduce Experiment 4 - Demonstrate with the small cube and beaker of water, request predictions and reasoning.

Action: Hold the small cube over the beaker of water.

Say: *I pick up this object and hold it over this beaker. If I place it into the liquid, will it float or sink? Check in the appropriate box under **Prediction 4** to indicate whether it will float or sink or whether there is not enough information.*

Students see:

Prediction 4: Check one. The cube will:

- float
- sink
- not enough information

Reasons for your answer (use full sentences):

Perform Experiment 4

Action: Using tongs, carefully place the small cube in the water. Once it has settled and it is clear that the cube has sunk, remove the cube from the liquid and dry it off.

Say: *Describe what I did and what happened in our experiment where it says **Observation 4**.*

Students see:

Observation 4 (use full sentences):

Record the details of our experiment.

Describe fully what the experimenter did and what happened as a result.

Present Thought Experiment 1 - Students consider possibilities with a “mystery cube” that has a different mass.

Action: Show the “mystery cube” to the class.

Say: *Now I have a new cube. Let’s call it the “**Mystery Cube.**” This cube is the **same size as the large cube we’ve been using. Let me tell you one more thing about this cube. It is NOT the same weight as the first cubes. Let’s consider two possibilities:***

*The mystery cube then is either **lighter** than the other cubes or **heavier** than the other cubes.*

For these two possibilities predict whether the cube will float or sink when I place it in these beakers or whether there is not enough information.

*Use the space provided for **Thought Experiment 1** to answer this question.*

Students see:

Thought Experiment 1:

Consider 2 possibilities. The mystery cube is either lighter than the other two cubes, or heavier than the other two cubes.

Considering both these possibilities, predict whether the mystery cube will float or sink in these beakers or whether there is not enough information.

Present Thought Experiment 2 - Students consider a “mystery liquid.”

Action: Show the tiny cube to the class.

Say: *Now let’s consider a **mystery liquid**. Imagine that we have a **cube 1 centimeter on each side and weighing 2 grams**. If we wanted this cube to float in a liquid what would the properties of this liquid have to be? Do **not** use the word “density” in your answer. Use the space provided for **Thought Experiment 2** to answer this question.*

Students see: **Thought Experiment 2:** What must the properties of the mystery liquid be if the cube is to float in it? Do not use the word “density” in your answer.

Present Optional Summary Question

Say: *If you have time left and have ideas or questions about floating and sinking now that you have seen the experiments, write your answer under **Summary Question**. Also, please feel free to share your thoughts about your experience in the comments section.*

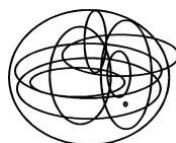

An **ACASE** Educational Assessment Activity
Association for the Cooperative Advancement of Science and Education
110 Spring Street, Saratoga Springs, N.Y. 12866, U.S.A.
phone (518) 583 4645
fax (518) 587 6467
www.acase.org